

Industrial Valve and Engineering Supplies (Pty) Ltd (IVES)

Valve and Engineering Merchant Company (Pty) Ltd (VEMCO)

Importers
Distributors



Brand Valves
Pipes and Fittings

Break Away
Brand Valves

FIG 7520

DIAPHRAGM VALVE SCR



TEST PRESSURE		
SIZES	BODY	SEAT
15/20MM	24KG/CM2	16KG/CM2

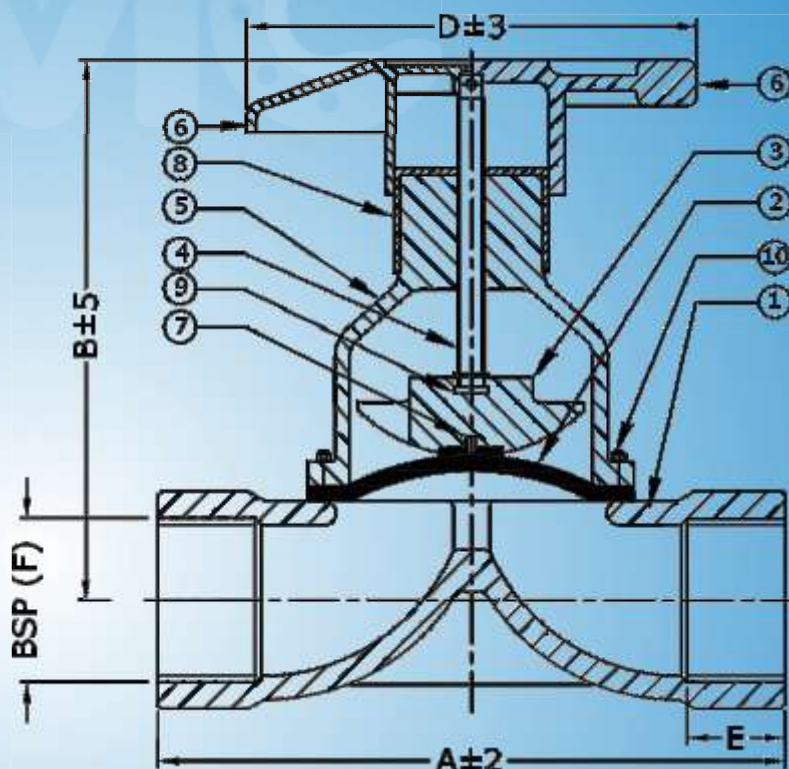

SIZE	WEIGHT
20MM	0.9KG

DIMENSIONS		
DN	15	20
A	65	84
B	85	99
D	62	62
E	9.5	12.5

MATERIAL SPECIFICATION		
SN.	COMPONENT	MATERIAL
1	BODY	ASTM A 395 (DUCTILE IRON)
2	DIAPHRAGM	EPDM
3	COMPRESSOR	ASTM A 216 Gr. WCB
4	SPINDLE	M.S.
5	BONNET	CAST IRON CASTING
6	HANDWHEEL	ABS PLASTIC
7	STUD.	Brass.
8	INDICATOR	P.P
9	THURSTDISK	NYLON
10	FASTENER	HI-TENSILE

TECHNICAL DATA

- MFG. STD: BS5156
MFG. STD: Revised.
BS EN 13397 : 2002.
- INSP & TEST STD: BS: 5146
- PRESSURE RATING: PN16
- END CONNECTION ASME B16.11

All Specifications are subject to change without notice

Head Office:

+27-11-394-2066 (21 Lines)
sales@industrialvalve.co.za
www.industrialvalve.co.za
114 Plane Road
Spartan
Gauteng
South Africa

KZN Branch:

+27-31-205-0218
laven@industrialvalve.co.za
www.industrialvalve.co.za
Unit 1.5
Canberra Park
Canberra Road
Umbilo
Durban

Cape Town Branch:

+27-21-982-0302
ivesct@industrialvalve.co.za
www.industrialvalve.co.za
Unit 14 Silver Park
Silver Street
Brackenfell
Cape Town