

*Break Away
Brand Valves*

Industrial Valve and Engineering Supplies (Pty) Ltd (IVES)

Valve and Engineering Merchant Company (Pty) Ltd (VEMCO)

**Importers
Distributors**



**Brand Valves
Pipes and Fittings**

FIG 2706FCI BMC LARGE CAPACITY FLOW RATE REMOTE FLOAT CONTROL VALVE

TEST PRESSURE (Bar)

API 598	SHELL	SEAT
HYDROSTATIC	24	17.6
AIR		--

Max Pressure Water : 16 Bar
Max Temp Water : 80 Deg C
Min Inlet Pressure : 2 Bar

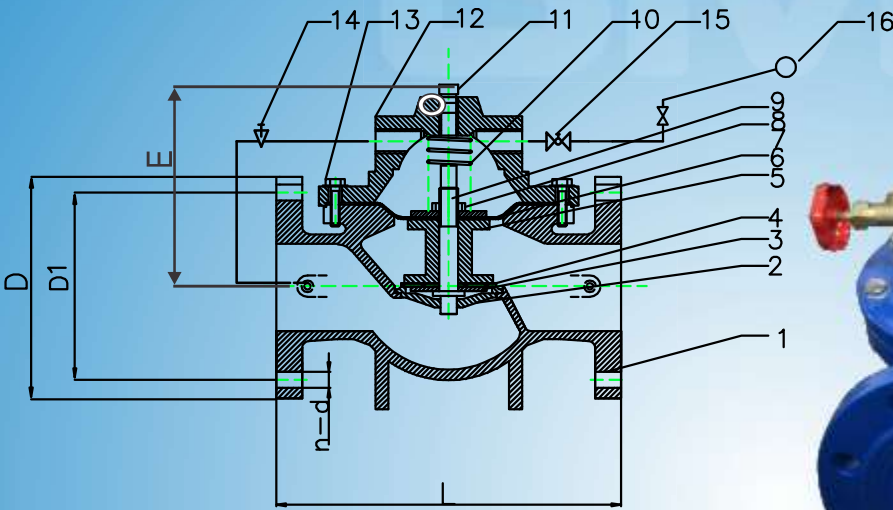

No	Part	Material
1	Body	DI
2	Seat	Brass
3	Platen	Carbon Steel
4	Seal	EPDM
5	Disc	DI
6	Diaphragm	EPDM
7	Platen	Carbon Steel
8	Nut	Stainless Steel
9	Stem	Stainless Steel
10	Spring	Stainless Steel
11	Plug	Brass
12	Bonnet	DI
13	Bolts	Stainless Steel
14	Needle	Brass
15	Globe Valve	Brass
16	Float Valve	Stainless Steel

Note: Valves Are Undrilled

DN	L	D	E	Weight Kg
50	215	165	140	9.5
65	235	185	155	15
80	250	200	160	16
100	290	220	170	20
150	360	285	240	37
200	420	340	270	65
250	450	405	340	121
300	510	450	435	162

All Specifications are subject to change without notice

Head Office:

+27-11-394-2066 (21 Lines)
sales@industrialvalve.co.za
www.industrialvalve.co.za
114 Plane Road
Spartan
Gauteng
South Africa

KZN Branch:

+27-31-205-0218
laven@industrialvalve.co.za
www.industrialvalve.co.za
Unit 1.5
Canberra Park
Canberra Road
Umbilo
Durban

Cape Town Branch:

+27-21-982-0302
ivesct@industrialvalve.co.za
www.industrialvalve.co.za
Unit 14 Silver Park
Silver Street
Brackenfell
Cape Town

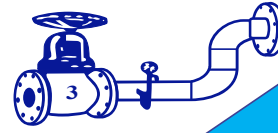

Industrial Valve and Engineering Supplies (Pty) Ltd (IVES)

Valve and Engineering Merchant Company (Pty) Ltd (VEMCO)

Importers
Distributors



Brand Valves
Pipes and Fittings

*Break Away
Brand Values*

FIG 2706FCI BMC LARGE CAPACITY FLOW RATE REMOTE FLOAT CONTROL VALVE

Flow Chart

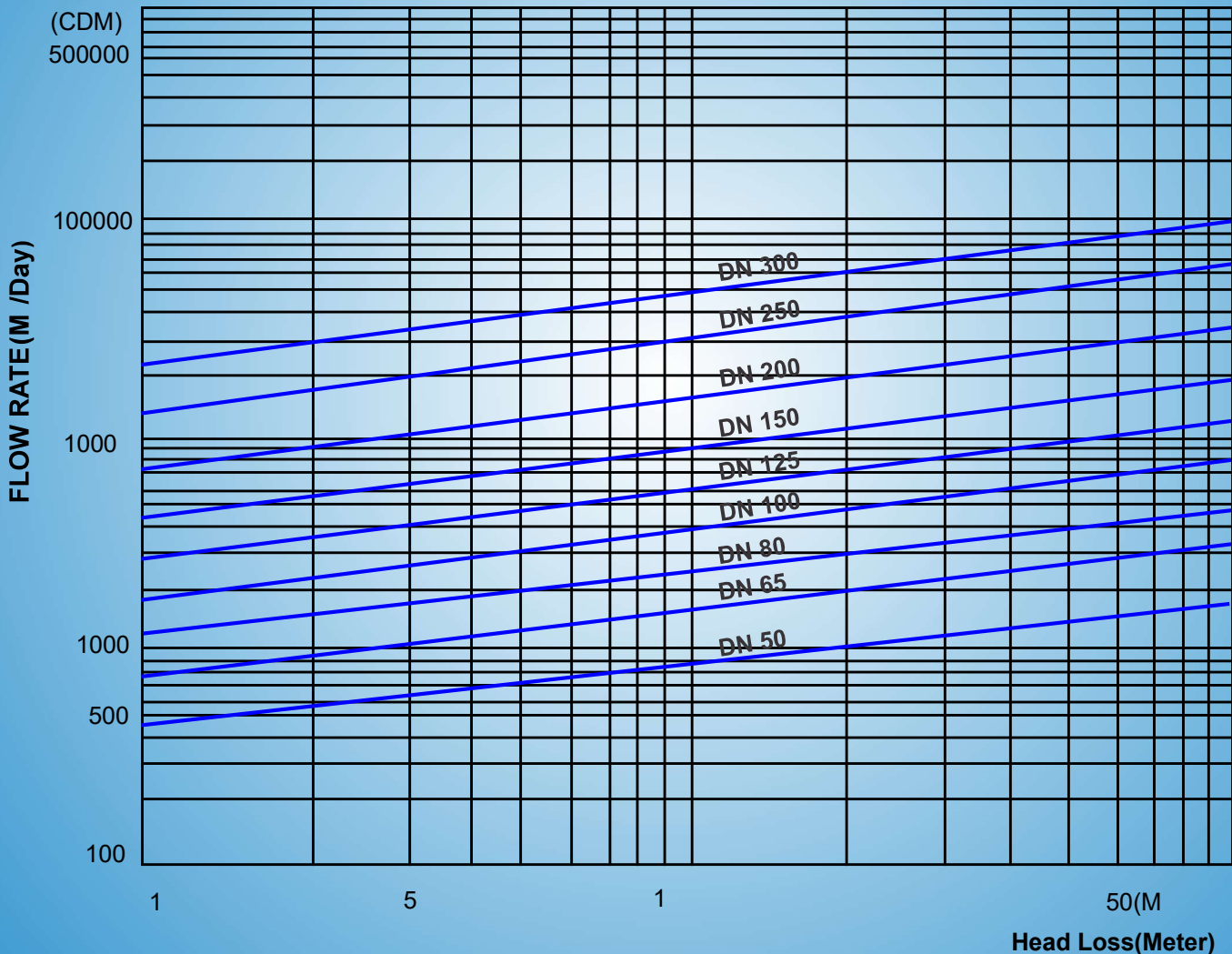

All Specifications are subject to change without notice

Head Office:

+27-11-394-2066 (21 Lines)
 sales@industrialvalve.co.za
 www.industrialvalve.co.za
 114 Plane Road
 Spartan
 Gauteng
 South Africa

KZN Branch:

+27-31-205-0218
 laven@industrialvalve.co.za
 www.industrialvalve.co.za
 Unit 1.5
 Canberra Park
 Canberra Road
 Umbilo
 Durban

Cape Town Branch:

+27-21-982-0302
 ivesct@industrialvalve.co.za
 www.industrialvalve.co.za
 Unit 14 Silver Park
 Silver Street
 Brackenfell
 Cape Town

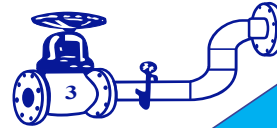

Industrial Valve and Engineering Supplies (Pty) Ltd (IVES)

Valve and Engineering Merchant Company (Pty) Ltd (VEMCO)

Importers
Distributors



Brand Valves
Pipes and Fittings

Break Away
Brand Values

FIG 2706FCI BMC LARGE CAPACITY FLOW RATE REMOTE FLOAT CONTROL VALVE

FLOAT CONTROL VALVE

Overview

A float valve is used to shut off the flow of liquids, normally water, at a pre-determined level. When adjusted and working properly a float valve is very accurate and extremely reliable.

When the water tank (pool) water rises to the set height, float ball to close the float valve to control the indoor water pressure, and promote the main valve closed, the water supply stops.

When the water drops, the float valve re-open the control room pressure drop, the main valve to open again to continue the water supply to maintain the liquid level of the set height.



Structure

Structure	Diaphragm
Working temperature	0? - 80?
Working pressure	PN10/PN16/PN25
Tubes/pilot valve	Brass
Seat	Brass
Spring/stem	Stainless steel
Bolts/washer	Stainless steel
Painting	Epoxy powder coated min 250µm
Body/Cover material	Cast iron/Ductile iron
Medium	Water
Port size	DN25-DN800 (1" to 32")
End flange connection	BS EN1092 PN10/PN16/PN25; ANSI Class125/150 FF/RF

All Specifications are subject to change without notice

Head Office:

+27-11-394-2066 (21 Lines)
sales@industrialvalve.co.za
www.industrialvalve.co.za
114 Plane Road
Spartan
Gauteng
South Africa

KZN Branch:

+27-31-205-0218
laven@industrialvalve.co.za
www.industrialvalve.co.za
Unit 1.5
Canberra Park
Canberra Road
Umbilo
Durban

Cape Town Branch:

+27-21-982-0302
ivesct@industrialvalve.co.za
www.industrialvalve.co.za
Unit 14 Silver Park
Silver Street
Brackenfell
Cape Town

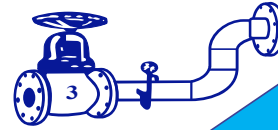

Industrial Valve and Engineering Supplies (Pty) Ltd (IVES)

Valve and Engineering Merchant Company (Pty) Ltd (VEMCO)

**Importers
Distributors**



**Brand Valves
Pipes and Fittings**

*Break Away
Brand Valves*

FIG 2706FCI BMC LARGE CAPACITY FLOW RATE REMOTE FLOAT CONTROL VALVE

Application

Suitable for water supply, Drainage & water circulation, Air-conditioning, Fire-fighting & Irrigation system, High-rise building and living area.

Drawing

- 1. Needle Valve
- 2. Ball Valve
- 3. Float Pilot Valve

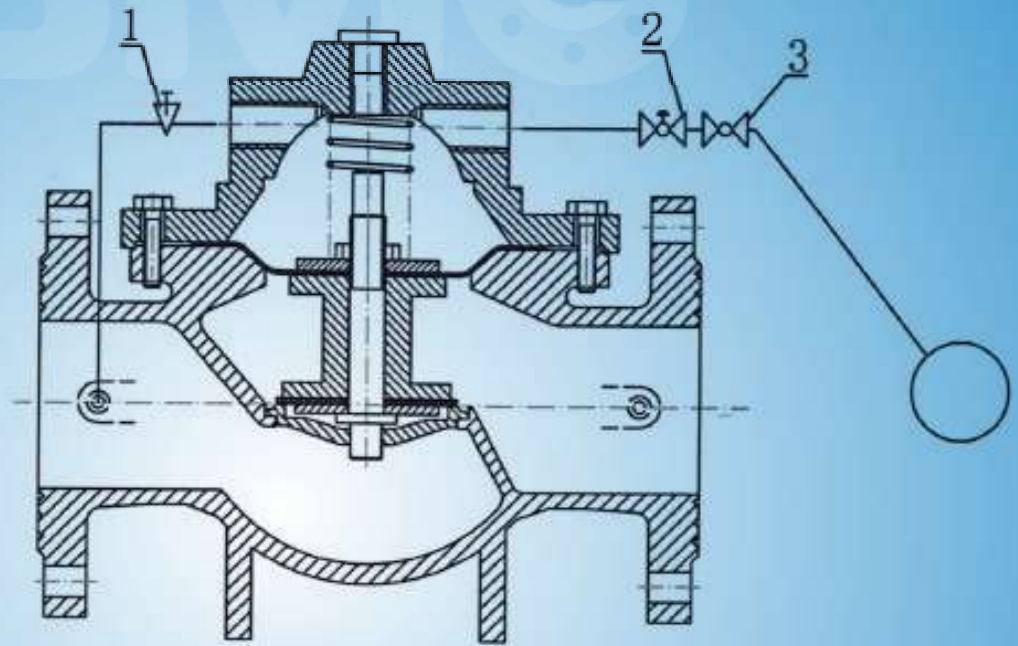

Installation Example

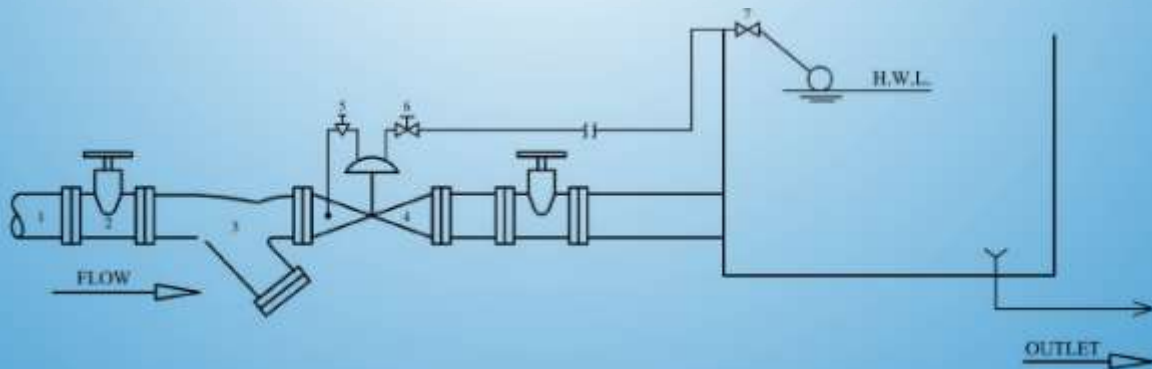

- 1. Main Supply Line
- 2. Gate Valve/Globe Valve
- 3. Y Strainer
- 4. Float Control Valve/Main Valve
- 5. Needle Valve
- 6. Ball Valve
- 7. Float Pilot Valve

All specifications are subject to change without notice

Head Office:

+27-11-394-2066 (21 Lines)
sales@industrialvalve.co.za
www.industrialvalve.co.za
114 Plane Road
Spartan
Gauteng
South Africa

KZN Branch:

+27-31-205-0218
laven@industrialvalve.co.za
www.industrialvalve.co.za
Unit 1.5
Canberra Park
Canberra Road
Umbilo
Durban

Cape Town Branch:

+27-21-982-0302
ivesct@industrialvalve.co.za
www.industrialvalve.co.za
Unit 14 Silver Park
Silver Street
Brackenfell
Cape Town

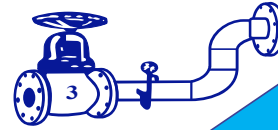

Industrial Valve and Engineering Supplies (Pty) Ltd (IVES)

Valve and Engineering Merchant Company (Pty) Ltd (VEMCO)

Importers
Distributors



Brand Valves
Pipes and Fittings

Break Away
Brand Valves

FIG 2706FCI BMC LARGE CAPACITY FLOW RATE REMOTE FLOAT CONTROL VALVE

- 1) Installation and Maintenance
 - i) The best installation method of the main valve is in a horizontal position although all other methods are acceptable.
- 2) Please ensure that the line is clean before installation of the valve.
- 3) Note that the valve can only be installed in one direction
- 4) It is advisable to install a gate valve and strainer before the control valve for maintenance purposes.
- 5) Once the line is under pressure, the gate valve should be gradually opened, increasing the pressure, taking note that the valve is functioning correctly.

Connection Schematic

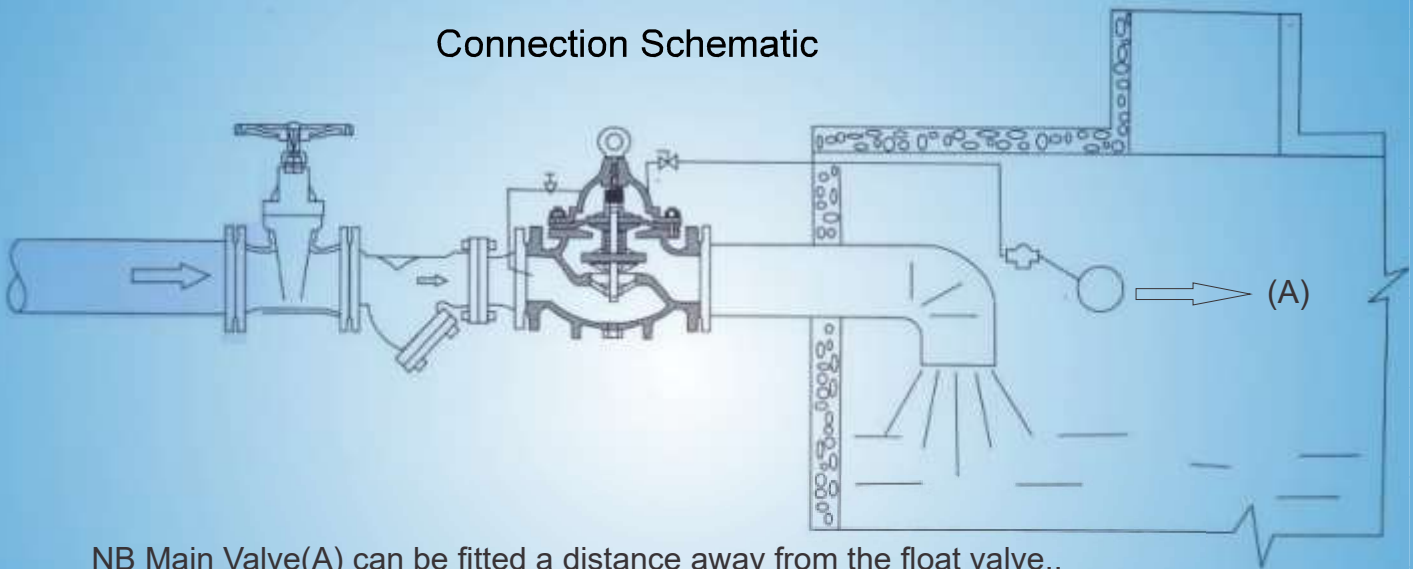

NB Main Valve(A) can be fitted a distance away from the float valve..



All Specifications are subject to change without notice

Head Office:

+27-11-394-2066 (21 Lines)
sales@industrialvalve.co.za
www.industrialvalve.co.za
114 Plane Road
Spartan
Gauteng
South Africa

KZN Branch:

+27-31-205-0218
laven@industrialvalve.co.za
www.industrialvalve.co.za
Unit 1.5
Canberra Park
Canberra Road
Umbilo
Durban

Cape Town Branch:

+27-21-982-0302
ivesct@industrialvalve.co.za
www.industrialvalve.co.za
Unit 14 Silver Park
Silver Street
Brackenfell
Cape Town