

Industrial Valve and Engineering Supplies (Pty) Ltd (IVES)

Valve and Engineering Merchant Company (Pty) Ltd (VEMCO)

Importers
Distributors



Brand Valves
Pipes and Fittings

*Break Away
Brand Values*

FIG 10

CAST IRON GATE VALVE RISING SPINDLE



Cast Iron Gate Valve Rising Spindle
Brass Seat And Gland
DIN3352-F4 Pattern
Face to Face According To DIN3202-F4

Primary Service Pressure Non Shock	Hydrostatic Test Pressure (psi)	
	Shell	Seat
16 Bar	24 Bar	17,6 Bar

NO	NAME	QTY	MATERIAL
1	BODY	1	GG25
2	SEAT	2	HT62
3	DISC	1	GG25
4	STEM	1	CARBON STEEL
5	STEM NUT	1	BRASS
6	BOLT		
7	NUT		
8	GASKET	1	GRAPHITE
9	GASKET		
10	BONNET	1	GG25
11	PACKING		GRAPHITE
12	GLAND	1	GG25
13	BOLT	2	
14	NUT GASKET	2	
15	STEM NUT	1	H62
16	HANDWHEEL	1	GG25
17	LOCKING NUT	1	GG25

Size	Weight Kg
DN50	18
DN65	23
DN80	30
DN100	37
DN125	54
DN150	70
DN200	105
DN250	147
DN300	189

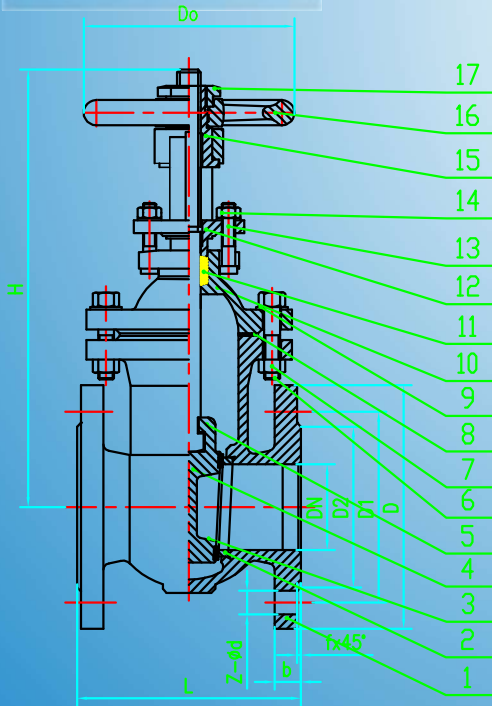

300	270	445/460	400/410	370/378	28	4	12-23/12-28	1190	320
250	250	395/405	350/355	320	26		8-23/12-23		
200	230	340	295	268	24		8-23		
150	210	285	240	212	22	3	8-19		
125	200	250	210	188	20		4-19/8-19	180	
100	190	220	180	158	18		4-19		
80	180	200	160	138					
65	170	185	145	122					
50	150	165	125	102					
40	140	150	110	88					
DN	L	D	D1	D2	b	f	Z-d	H	Do

All Specifications are subject to change without notice

Head Office:

+27-11-394-2066 (21 Lines)
sales@industrialvalve.co.za
www.industrialvalve.co.za
114 Plane Road
Spartan
Gauteng
South Africa

KZN Branch:

+27-31-205-0218
laven@industrialvalve.co.za
www.industrialvalve.co.za
Unit 1.5
Canberra Park
Canberra Road
Umbilo
Durban

Cape Town Branch:

+27-21-982-0302
ivesct@industrialvalve.co.za
www.industrialvalve.co.za
Unit 14 Silver Park
Silver Street
Brackenfell
Cape Town