

INDUSTRIAL VALVE AND ENGINEERING SUPPLIES (Pty) Ltd. / VEMCO (Pty) Ltd

VAT REG NO: 4280104276 CO REG NO 83/05965/07

VAT REG NO:4200211854 CO REG NO 1979/002851/07



Head Office: 114 Plane Road, Spartan, Gauteng
Tel: 27-11-394-2066 (21 LINES)
Fax: 27-11-394-2476
E-Mail: industrialvalve@futurejhb.co.za
Web: www.industrialvalve.co.za

Durban: 499 Sydney Rd, Harbour Bridge Park
Unit 14, Durban
Tel: 27-31-205-0218
Fax: 27-31-205-0210
E-Mail: iveskzn@futurejhb.co.za

Nelspruit: 19 Tabak Str
Nelspruit
Tel: 27-13-752-2372
Fax: 27-13-752-8079
E-Mail: ivesnelspruit@industrialvalve.co.za



BREAKAWAY HYDRAULIC TEST PUMPS

HTP 501

CAPACITY: 100 BAR
COMPLETE WITH: TEST PUMP, STAND, PRESSURE GAUGE, 1M HP HOSE, 3M LP HOSE.
DRAWS WATER FROM A BUCKET OR FITS ON A 44 GALLON DRUM.

Standard Pressure Gauge: 0-6000 Kpa



Strokes Per Litre: 26

HTP 502

CAPACITY: 200 BAR
COMPLETE WITH: TEST PUMP, STAND, PRESSURE GAUGE, 1M HP HOSE, PLUS SPECIAL WATER MAINS INLET.

Standard Pressure Gauge: 0-6000 Kpa

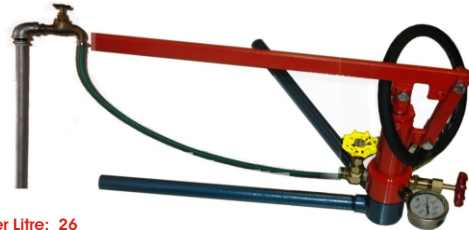

Strokes Per Litre: 26

HTP 503, 503HP, 503HC

CAPACITY: HTP 503: 200 BAR Std Pressure Gauge 0-6000 Kpa
HTP 503HP: 300BAR Std Pressure Gauge 0-40 Mpa
HTP 503HC: 100 BAR Std Pressure Gauge 0-6000 Kpa

COMPLETE WITH: TEST PUMP, CONTAINER, PRESSURE GAUGE, 1M HP HOSE



Strokes Per Litre:
HTP503: 26
HTP503 HP: 60
HTP503HC: 22

HTP 504, 504HP, 504HC

CAPACITY: HTP 504: 200 BAR Std Pressure Gauge 0-6000 Kpa
HTP 504 HP: 300 BAR Std Pressure Gauge 0-40 Mpa
HTP 504 HC: 100 BAR Std Pressure Gauge 0-6000 Kpa

COMPLETE WITH: TEST PUMP, CONTAINER, PRESSURE GAUGE, 1M HP HOSE, PLUS SPECIAL WATER MAINS INLET WITH NEEDLE VALVE REGULATION

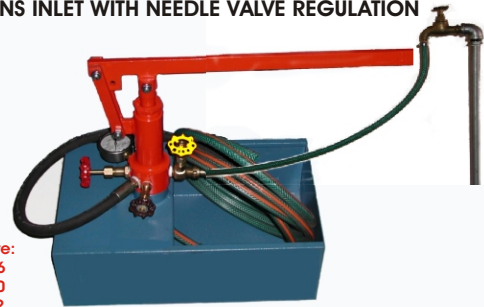

Strokes Per Litre:
HTP504: 26
HTP504 HP: 60
HTP504HC: 22

HTP 505

CAPACITY: 200 BAR Std Pressure Gauge 0-6000 Kpa

COMPLETE WITH: TEST PUMP, CONTAINER, PRESSURE GAUGE, 1M HP HOSE

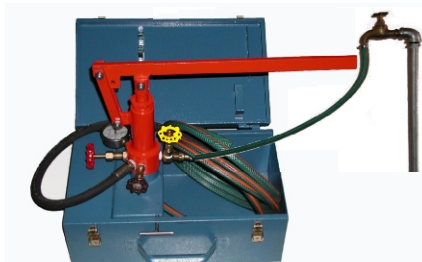

Strokes Per Litre: 26

PLUS

- 1) Fold up carry case
- 2) Low pressure (high capacity) pump
- 3) High pressure pump
- 4) Light weight stand
- 5) Adjustable handle
- 6) 3m LP Hose with tap connection
- 7) Detachable lid
- 8) Special water mains inlet supply needle valve for regulation

ALL SPECIFICATIONS ARE SUBJECT TO CHANGE WITHOUT NOTICE

Break Away
VALVES

TECHNOLOGY AT ITS BEST

INDUSTRIAL VALVE AND ENGINEERING SUPPLIES (Pty) Ltd. / VEMCO (Pty) Ltd

VAT REG NO: 4280104276 CO REG NO 83/05965/07

VAT REG NO:4200211854 CO REG NO 1979/002851/07



Head Office: 114 Plane Road, Spartan, Gauteng
Tel: 27-11-394-2066 (21 LINES)
Fax: 27-11-394-2476
E-Mail: industrialvalve@futurejhb.co.za
Web: www.industrialvalve.co.za

Durban: 499 Sydney Rd, Harbour Bridge Park
Unit 14, Durban
Tel: 27-31-205-0218
Fax: 27-31-205-0210
E-Mail: iveskzn@futurejhb.co.za

Nelspruit: 19 Tabak Str
Nelspruit
Tel: 27-13-752-2372
Fax: 27-13-752-8079
E-Mail: ivesnelspruit@industrialvalve.co.za



BREAKAWAY HYDRAULIC TEST PUMP INSTRUCTIONS

PROCEDURE A: FOR USE ON ALL MODELS REF. NO.'S 501,502,503,504,505,506.

1. When ordering HTP, make sure that you have selected and fitted the correct gauge, according to your required test pressure.
2. Make sure the container is clean, fill container with clean water (IF possible add soluble oil to water to prevent rusting) on Ref. No's 503,504,505,506 and/or
 - 2a. On Ref. No.'s 502,504,505,505,506, an optional or alternative water supply can be used by connecting your low-pressure garden hosepipe mains onto No. 1 of the test pump. (You do not necessarily need to fill the container with the water if this method is used.)
Once the hose pipe is connected, open the yellow hand wheel Ref. No. 1 and the red handwheel, Ref. No. 5 fully, close No7 Brown Hand wheel, and then open your L/P tap water supply.

BEWARE The handle Ref. 2 might rise: The Water will automatically push through the test pump to the unit to be filled without having to pump the test pump at all. Once the unit is filled with water, you can now start pumping until you obtain the test pressure required.

3. For high pressure pumping: Select 2a of the handle for high pressure pumping or 2b for lower pressure pumping.

PROCEDURE B: PREPARATION FOR ALL BREAKAWAY H.T.P. MODELS

1. Close red handle Ref. 5 and brown hand wheel Ref. 7 and pump handle Ref. 2 until it becomes hard and unable to pump. DO NOT FORCE (No pressure reading will occur on pressure gauge) Should this not happen, clean seat and/or tighten gland packing nut.
 2. After not being able to push the handle down, now release red handwheel, Ref. 5 only and pump until water comes out of hose. (Your pump is now ready for use)
 3. Connect H.P. hose Ref. 6 onto the item for testing, but make sure that you have prefilled the vessel with water that's to be tested.
 4. Pump handle Ref.2 until you obtain required test pressure.
 5. Once test pressure is obtained, close red handwheel Ref. 5 and carry out your testing requirements.
 6. To release pressure, open brown handwheel Ref. 7.
 7. To prevent rust, whilst NOT IN USE: Wash the unit out after use with soluble oil.
- N.B. On Ref. No.'s 501, 502, 503, 504, 505, 506, 26 strokes of the handle will give approximately 1 litre of water.

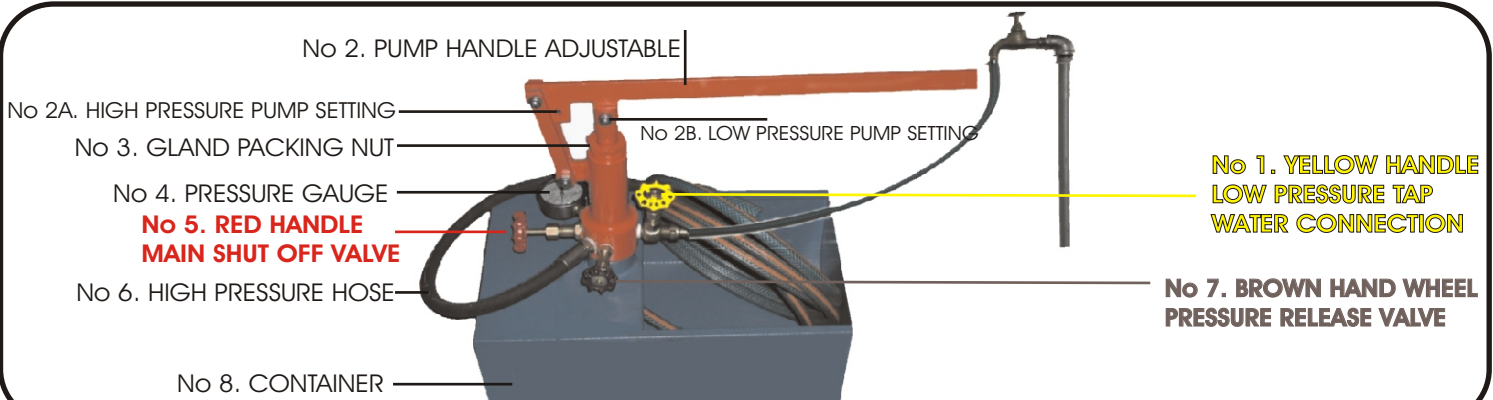

ALL SPECIFICATIONS ARE SUBJECT TO CHANGE WITHOUT NOTICE

Break Away
VALVES

TECHNOLOGY AT ITS BEST